

CARVART – Contract

INSTALLATION INSTRUCTIONS FOR:

-glassBOARDS Stand-Off

GENERAL

These installation instructions are meant for industry professionals. If you are not trained to install glass products or to adequately anchor contract products and other architectural products for safe use, please contact your dealer and obtain the services of an industry professional. Carvart is not responsible for means and methods of anchoring and fastening glass and metal products. These installation instructions are meant as a guide, and to recommend industry standards based on previously installed projects and standard applications of use. These instructions serve to guide installation for an efficient and time-sensitive set up and, in no way, indicate means of fastening or specify anchors or substrate quality or strength. Carvart is not responsible for the structural integrity of the substrate to which the Carvart products are fastened and is not responsible for means and methods of hanging, supporting or fastening Carvart products to other substrates or products.

This document is intended for the above listed products only. If you do not have proper installation instructions for the Carvart product you are installing, please contact your dealer or service representative. Carvart reserves the right to change, modify and update this document at any time. Please contact your dealer for the current installation instructions.

Glass panels should always be stored in the original crate and transported in an appropriate L-Card with the bottom edges supported by soft padding (rubber pads are best). Do not allow hard or abrasive materials to come in contact with the glass edges.

SECTIONS IN THIS DOCUMENT

- I. Components (Products included with this shipment)
- II. Recommended Tools
- III. Set up
- IV. Installation

I. COMPONENTS

- Glass panel(s) (refer to PO and packing list for quantity and finishes)
- Stand-Offs (quantity specified in PO and packing list)

The following recommended components (NOT supplied by Carvart) should be used only according to manufacturer's instructions on designated materials and substrates, with proper preparation:

*** Carvart is not responsible for anchoring strength, fastener selection or substrate integrity. All means and methods of fastening and installation are solely the responsibility of the installer. The below recommended products are based on industry standards and previous installation examples. Carvart is a manufacturer and not an installation company; all installation practices here are meant as a recommendation only.*

- Self-taping fasteners (type and length to be specified by installer)
- Toggle Bolts (recommended: heavy-duty pull zip toggles, example below)

Example of toggle bolt:

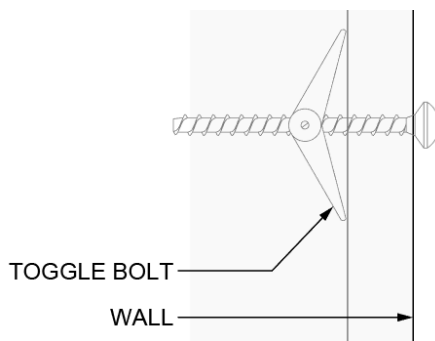

Example of wall blocking:

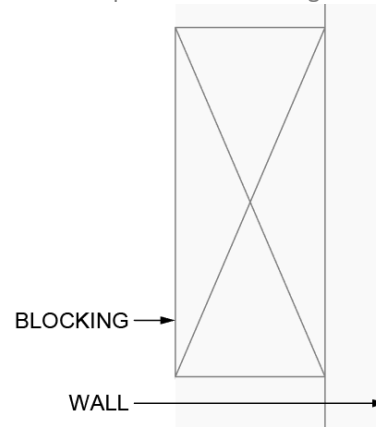

II. RECOMMENDED TOOLS

- Laser or level
- Tape Measure
- Pencil or chalk
- Fasteners for stand-offs (must be compatible with substrate and user-provided blocking; toggle bolts may also be used but are not recommended as their support is not as strong as that of fasteners into blocking)
- Electric drill/screwdriver
- Suction cups
- 2 men (3 recommended depending on the size of the Carvart product)

III. SET UP

1. Pre-construction and according to a trained industry professional's guidelines, determine the optimal placement location(s) for the product.

2. a. Determine what type of blocking is in the partition or substrate and ensure this is adequate for fastening the weight of the panel.

- For existing walls without blocking:

If no continuous blocking exists, Stand-Offs should be fastened to studs. Locate wall studs along the width of the product mount area. It is strongly advised that set screws be secured into at least 2 studs top and bottom.

If no studs can be found or used for fastening, heavy-duty pull zip toggle bolts can be used as an alternative. Carvart recommends mechanically fastening all Stand-Offs to continuous blocking.

- For construction walls with blocking:

Add 12" x 3/4" plywood blocking between studs at the intended top and bottom heights of the product to sit behind drywall.

b. With laser or level, set heights on the wall or partition to which the Carvart product will be fastened to. With a pencil or chalk, establish the heights shown in the diagram below where stand-offs will be fastened according to the offset dimensions in step c of set up.

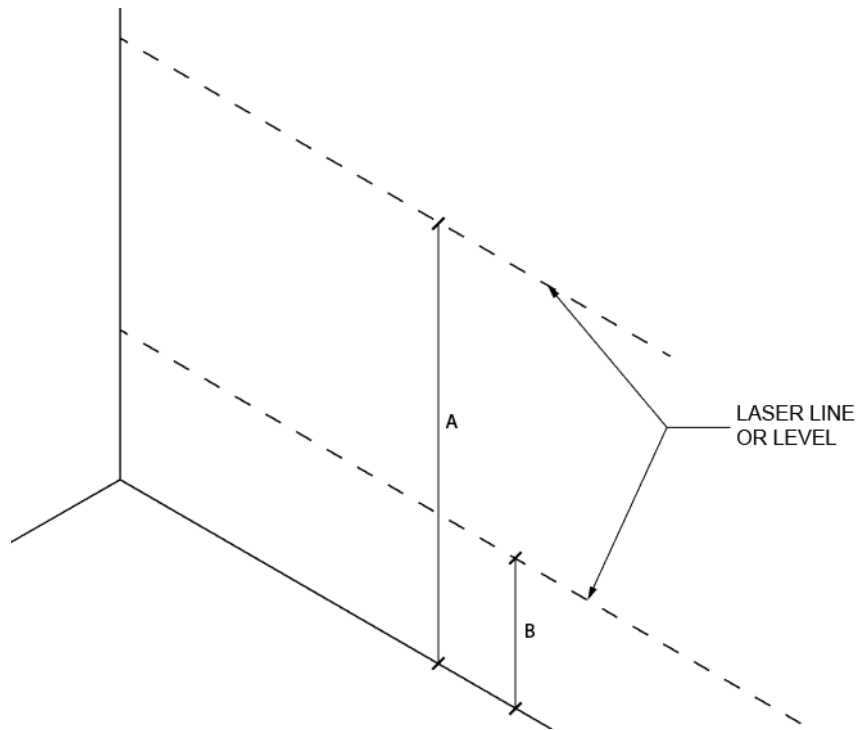

c. Use the offset in the diagrams below to mark pilot holes as they relate to the glass panel offset shown below for top and bottom stand-offs. Stand-Offs are designed to mount 2" off each left and right side at the corners. For larger boards requiring 6-to-8 total stand-offs, center stand-offs would be spaced equally across visually. See diagrams below for specific product offsets and dimensions.

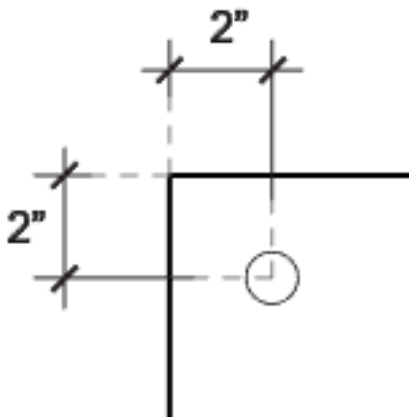

Corner Detail

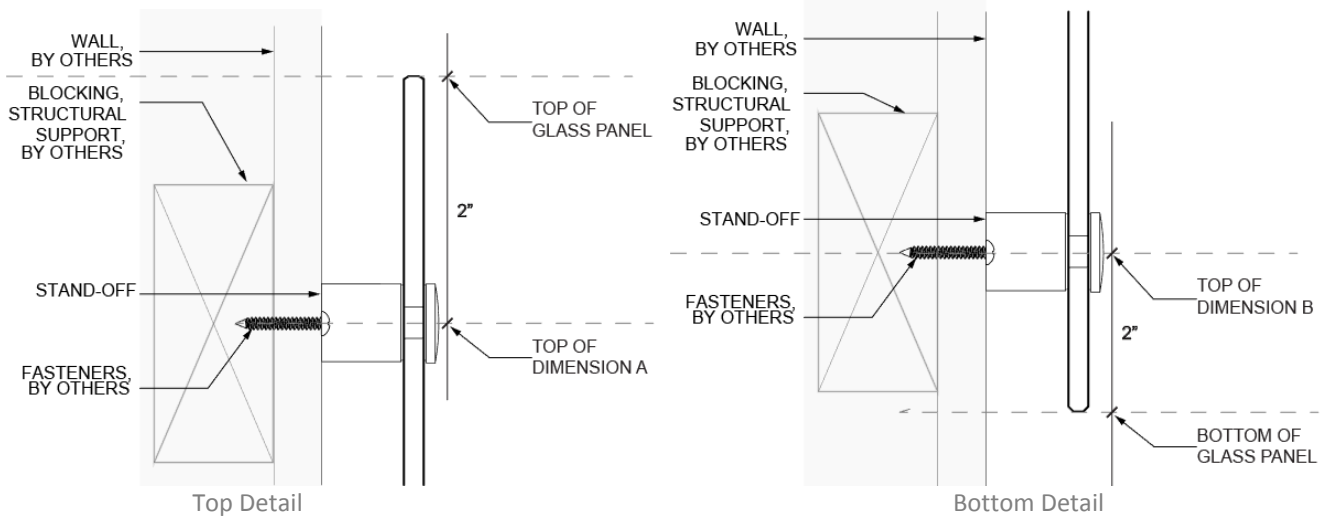

IV. INSTALLATION

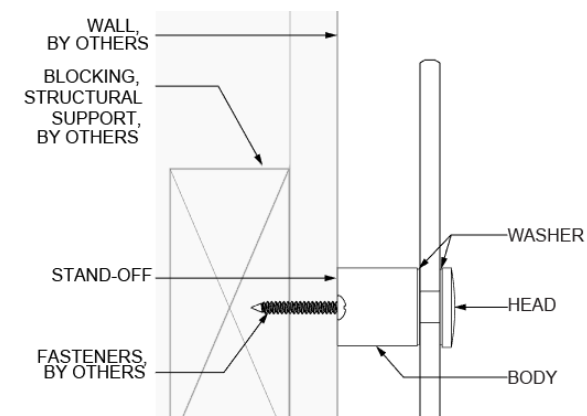

With a minimum of 2 persons (3 is recommended for large panels), lift up the board using suction cups according to manufacturer's instructions, or carefully by hand. Tighten the lower Stand-Offs first with the provided Allen Wrench, then put the top heads in place. Once all bodies are secured in-place, washers and heads must be secured to support the board. **CAUTION:** Please ensure panels are securely locked into stand-offs. Ensure glass is fully protected when securing or adding pressure. Glass should not come in contact with metal, stone or any other hard surface. Carpet, wood and neoprene gaskets should be used along with suction cups with handling glass products.